

Sliding Door Gear

Sliding Door Gear

A range of heavier duty, top-hung sliding door gear for interior or exterior use. These systems are designed for use on heavier doors in factories, hospitals and industrial applications. The systems are in component form.

To specify or order a system is easy, first select which system is most appropriate for the application based on the opening size, door mass etc from the table below, choose either the 100, 200 or 300 system. The systems are then split into 6 different sections. Choose the parts for the appropriate system from the following sections:-

1. Top Track
 2. Brackets
 3. Hangers
- Then either;
4. Bottom Guides
 5. Bottom Channel
- Or;
6. Popular and easier alternatives to the Bottom Guide & Channel system (4 & 5)

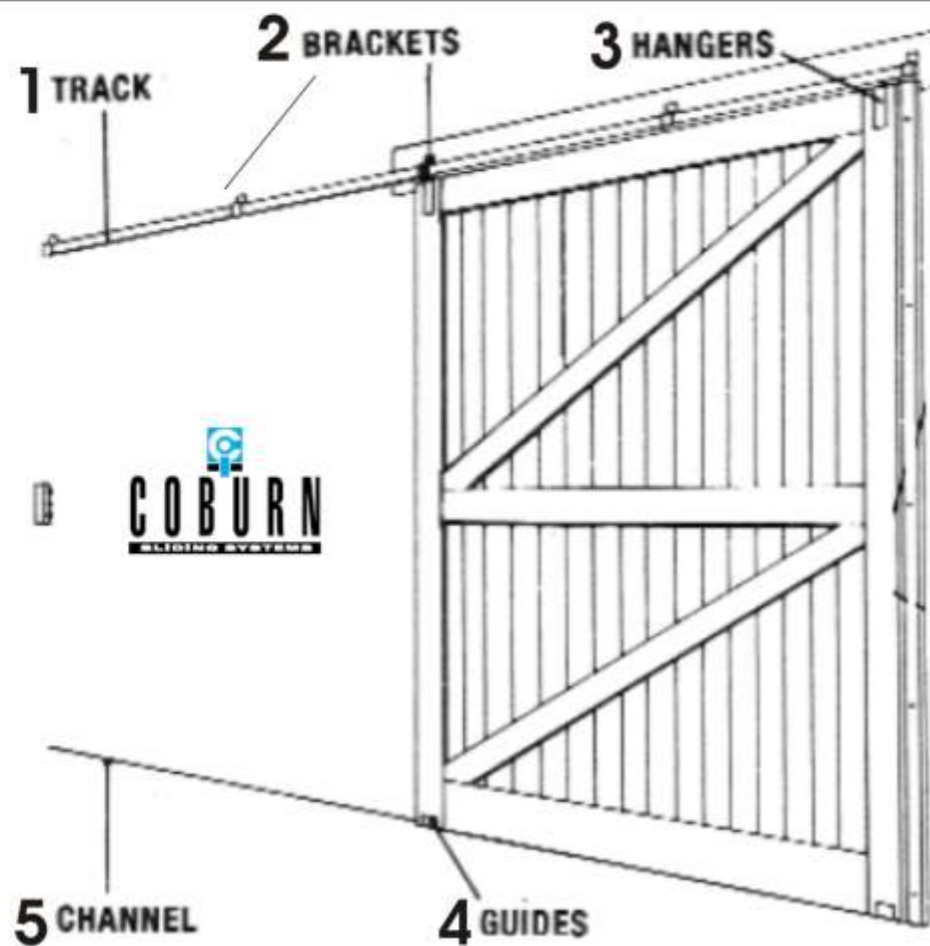

System	Door Thickness	Max Door Weight	Max Door Height
100	20 - 50mm	100kg	2500mm
200	35 - 44mm	200kg	4000mm
300	44- 57mm	400kg	5000mm

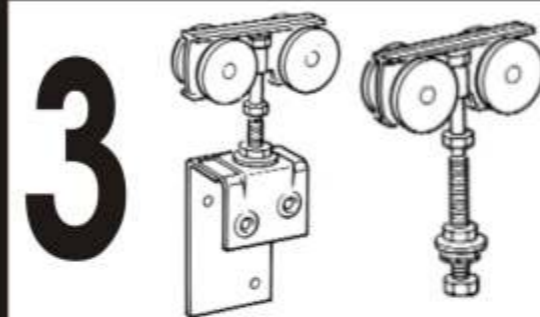

Description	Product Code		
	100 System	200 System	300 System
4 Wheel Door Hanger. For timber doors. In pairs.	SG181	SG281	SG381
4 Wheel Door Hanger. For metal doors. In pairs.		SG292	SG392

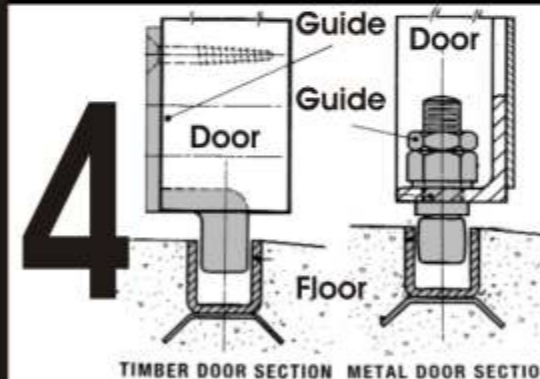

Description	Product Code		
	100 System	200 System	300 System
Bottom Guide. For timber doors 44-57mm	SG500		
Bottom Guide. For metal doors.	SG44315		



Description	Length (mm)	Product Code		
		100 System	200 System	300 System
Bottom Channel , manufactured from cold, rolled, galvanised steel. Specifically designed for maximum strength and durability.	1800	SG44118		
	2100	SG44121		
	2400	SG44124		
	3000	SG44130		



Description	Length (mm)	Product Code		
		100 System	200 System	300 System
Steel Top Track , manufactured from cold, rolled, galvanised steel. Specifically designed for maximum strength and durability.	1800	SG161	SG261	SG360
	2100	SG162	SG262	SG363
	2400	SG163	SG263	SG363
	3000	SG164	SG264	SG364



Description	Product Code		
	100 System	200 System	300 System
Open Face Fixing Bracket (pictured). Max. bracket spacing: 900mm.	SG171	SG271	SG371
End Bracket Kit. Converts the Open Face Fix Bracket to a stop-end type bracket. In pairs	SG172	SG272	SG372
Joint Bracket Kit. Converts the Open Face Fix Bracket to joint type bracket for butt joints in Top Track.	Not available	SG273	SG373

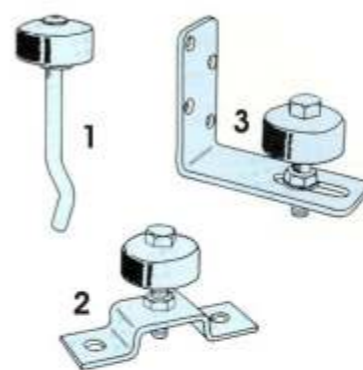

Description	Product Code		
	100 System	200 System	300 System
1. Bottom Roller Guide Cast-in Type	SG931		
2. Bottom Roller Guide Floor fix type	SG934		
3. Bottom Roller Guide Wall fix type	SG933		

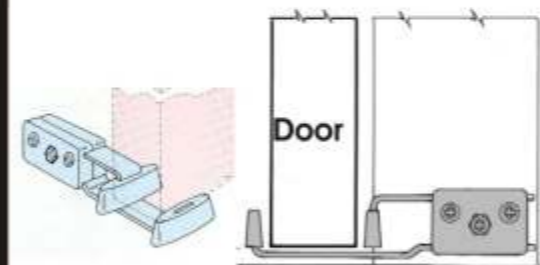

Description	Product Code		
	100 System	200 System	300 System
Reveal Mounted Bottom Guide. For timber doors up to 44mm thick. For internal doors only.	SG197	Not available	Not available

We also stock a full range of accessories including industrial strength Stops, Bow Handles and Flush Handles.

